



# Heliospectra LED Grow Lights



Fully customisable Grow Chamber and Environmental Control Room solutions.





MineARC Systems have been at the forefront of controlled environment design, development and manufacture for over 20 years; striving to improve the health and safety standards within the mining, tunnelling, chemical processing, disaster relief and extreme weather industries worldwide. MineARC Systems' industry leading refuge chambers and safe havens are present in over 60 countries and have been used in multiple real-life emergencies to keep occupants safe.

MineARC's key focus on quality control and product development has meant that all MineARC Refuge Chambers and Safe Havens comply with the highest international regulations and recognised 'world's best practice' industry guidelines.

In-house research and development with our team of engineers, electrical designers, technical experts, as well as production and service technicians has allowed us to branch out into multiple industries over the years. Our knowledge and proficiencies have



Heliospectra was founded in 2006 in Sweden by plant scientists and biologists with one vision – to make crop production more intelligent and resource-efficient. Today, with customers spanning six continents, Heliospectra is the global leader in innovative horticulture lighting technology, custom light control systems and specialized services for greenhouse and controlled plant growth environments.

#### **Innovation**

Heliospectra provide the most advanced crop lighting, controls and services to customers across six continents.

#### **Expertise**

Their team consists of plant biologists and actual growers who understand your growing needs.

now given us the opportunity to gain recognition beyond our refuge chambers and safe havens and expand into the science and research industries. Our Biora Grow Chamber is a perfect solution for controlled environment agriculture and climatic stability testing.

As advocates of innovation, our dedication to ongoing research and development is driven by our emphasis on client satisfaction. MineARC listens to and understands the needs of our clients, whilst never compromising on safety and quality. Placing a high importance on building strong relationships with our clients allows us to develop unique and customised solutions. This approach enables us to improve research and growth facilities, reduce costs and simplify operations.

[www.minearc.com](http://www.minearc.com)

#### **Collaboration**

Rooted in plant and light research, Heliospectra partner with you from seed to harvest.

#### **Quality**

Premium solutions designed to maximize the quality of your crops in every growing environment.

#### **Sustainability**

They help you consistently produce sustainable and resource efficient nutritious crops

#### **Passion**

Heliospectra's passion is to redefine nature's potential, so that together we can feed and heal the world.

[www.heliospectra.com](http://www.heliospectra.com)



Explore Heliospectra's market-leading range of LED Grow Lights; sold & supported by MineARC Systems.

# MITRA

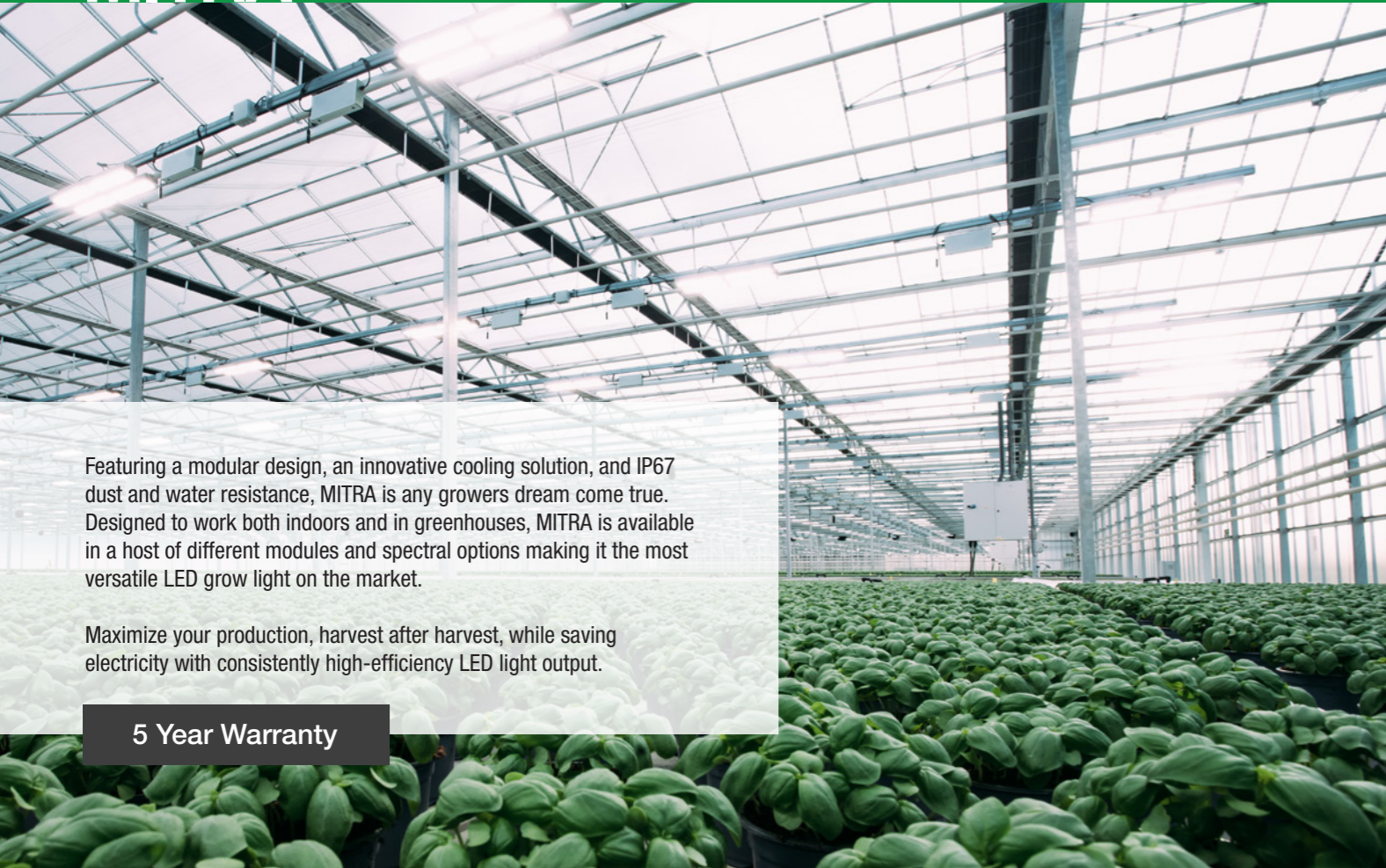

Featuring a modular design, an innovative cooling solution, and IP67 dust and water resistance, MITRA is any grower's dream come true. Designed to work both indoors and in greenhouses, MITRA is available in a host of different modules and spectral options making it the most versatile LED grow light on the market.

Maximize your production, harvest after harvest, while saving electricity with consistently high-efficiency LED light output.

**5 Year Warranty**

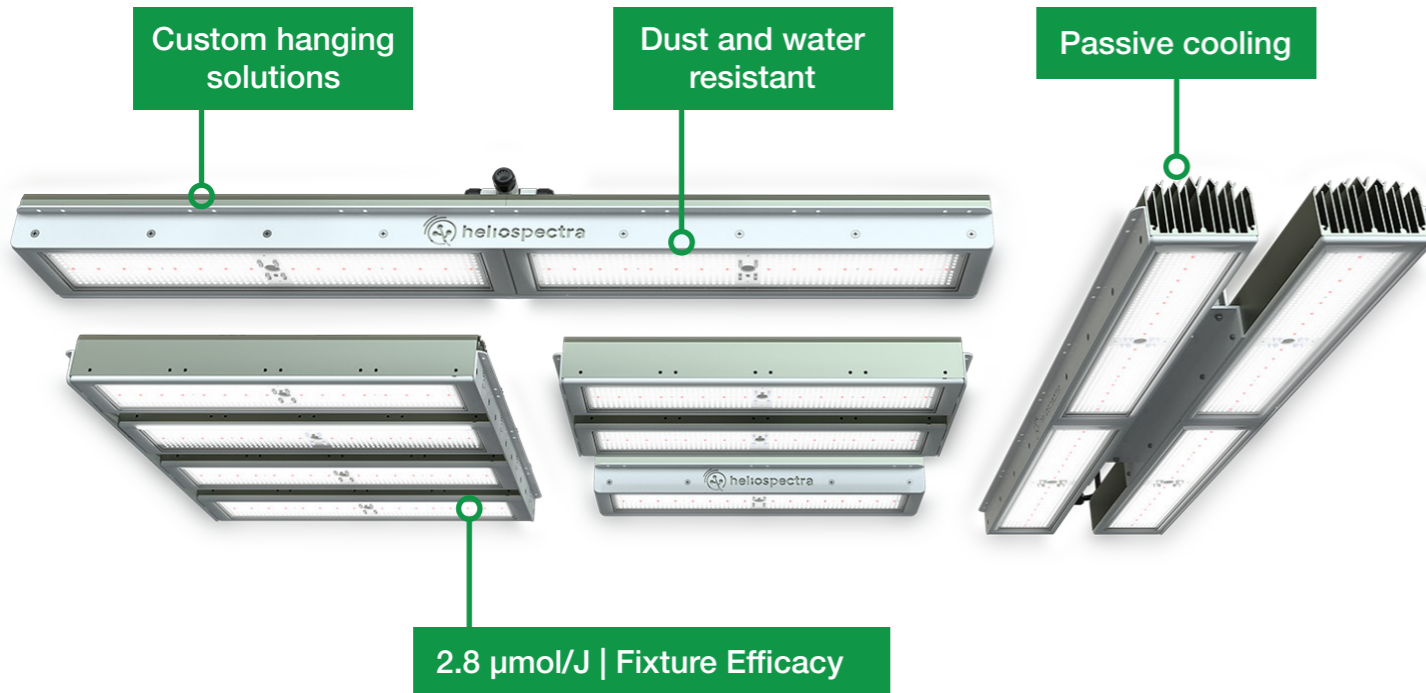

# MITRA

Power factor	ATHD	Max ambient	Thermal management	Heat value	Life time	Beam angle	Control	Plug options	Cable length
>0.97	<10%	40°C	Passively convection cooled	2217 BTU/hr	Q90 > 46,000 h	118°	0-10V dimming	Open-ended	3m PSU to lamp 2m PSU to plug

## Installation Specifications

Model	Weight	Mounting
<b>Square</b>	12kg	Hole profile
<b>Linera</b>	13.5kg	C-bracket
<b>Split</b>	13.5kg	Hole profile
<b>Power supply</b>	6kg	Hole profile

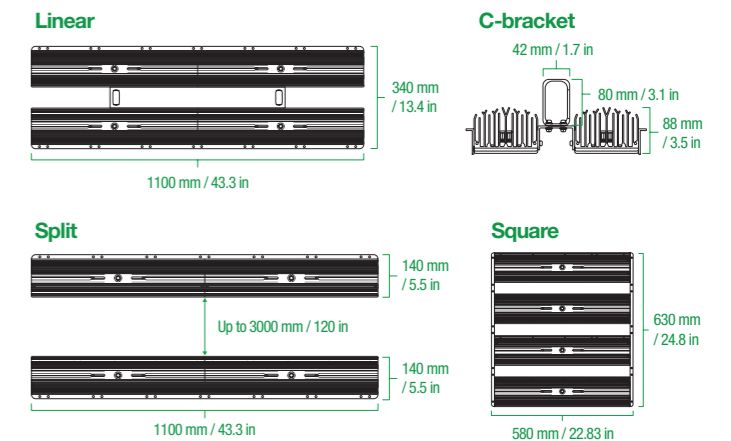

## Power Supply

Input voltage	230 VAC	277 VAC	347 VAC	400 VAC	480 VAC
<b>Input current</b>	2.34 A	2.32 A	1.99 A	1.72 A	1.36 A
<b>Power</b>	650 W	641 W	639 W	637 W	634 W

<b>IP rating</b>	IP67
<b>Certifications</b>	ETL, CE, Dry and damp location
<b>Warranty</b>	5 years
<b>Voltage range</b>	200 to 480 VAC

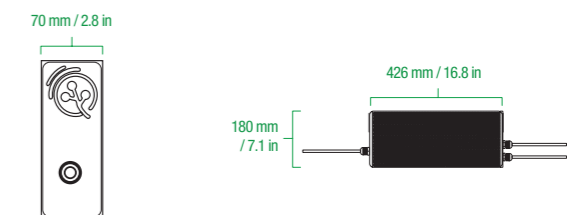

## Spectral Variants

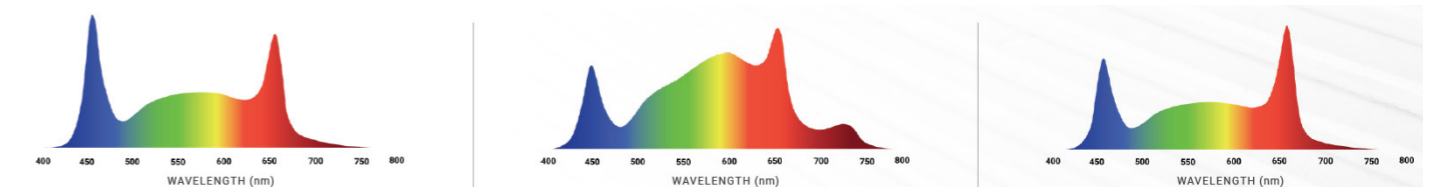

\*Output measurements include Far-red.

**helioSPEC Vega**  
 Light output (PF): 1800 μmol/s\*  
 Efficacy (PE): 2.8 μmol/J\*  
 CRI: 91.1

**helioSPEC Lyra**  
 Light output (PF): 1700 μmol/s\*  
 Efficacy (PE): 2.7 μmol/J\*  
 CRI: 89.1

**helioSPEC Bellatrix**  
 Light output (PF): 1800 μmol/s\*  
 Efficacy (PE): 2.8 μmol/J\*  
 CRI: 93.9

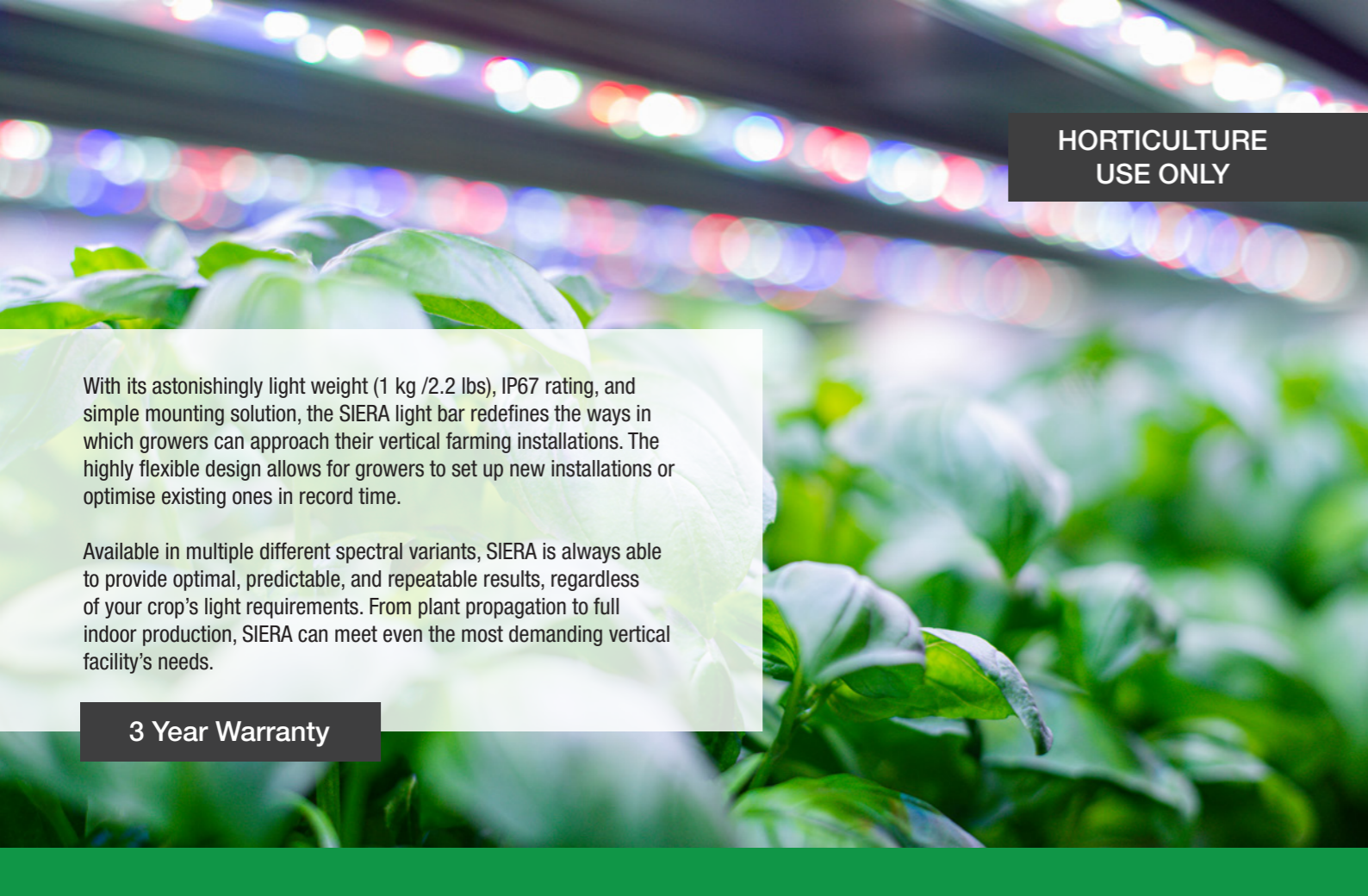

**HORTICULTURE  
USE ONLY**

With its astonishingly light weight (1 kg /2.2 lbs), IP67 rating, and simple mounting solution, the SIERA light bar redefines the ways in which growers can approach their vertical farming installations. The highly flexible design allows for growers to set up new installations or optimise existing ones in record time.

Available in multiple different spectral variants, SIERA is always able to provide optimal, predictable, and repeatable results, regardless of your crop's light requirements. From plant propagation to full indoor production, SIERA can meet even the most demanding vertical facility's needs.

**3 Year Warranty**

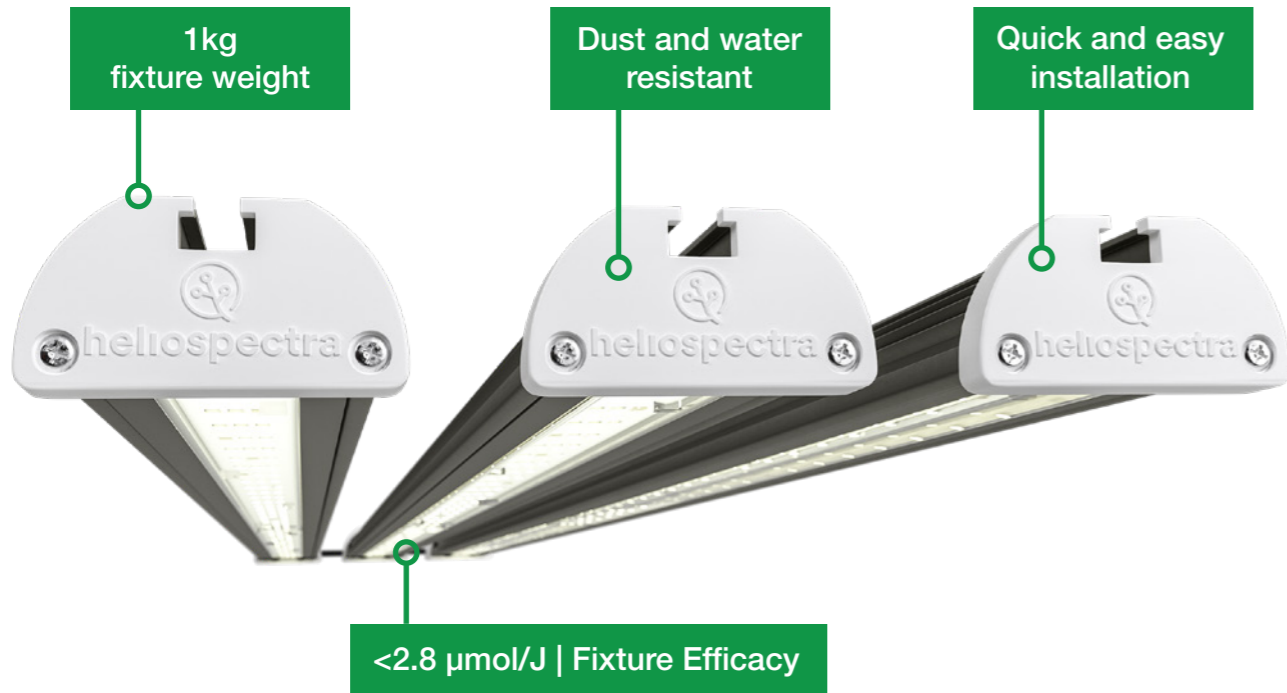

Wattage	Dimensions	Weight	Heat value	Thermal management	Max ambient	Life time	Power factor	Beam angle	Control
0-46 W	25 x 50 x 1165 mm	1kg	Up to 157 BTUs/hr	Passively convection cooled	40 °C (104 F)	Q90 > 46 000h	> 0.95	119°	0-10V Dimming on Power Supply

## Installation Specifications

Top View



Side View



Bottom View

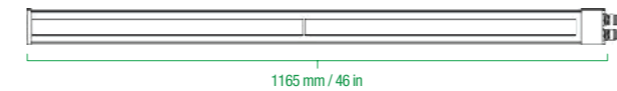

Mounting	Cable Length Alternatives
Built in T-slot (M6 Bolt)	3m (9ft 10in) 1.5m (4ft 11in) 0.5m (1ft 7in)

Front View



Rear View

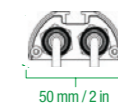

## Power Supply

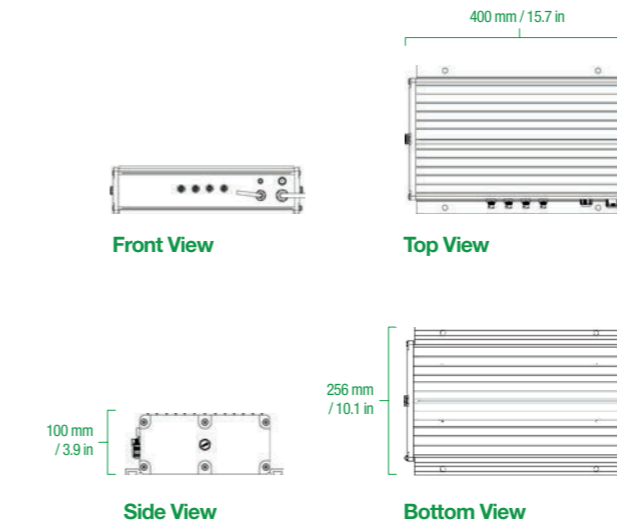

Voltage	120 VAC	240 VAC
Amperage	5A	2.5A
Frequency	50/60 Hz	
Plug Type	Open ended	
Wattage	600W	
Parallel VDC Channels	Supports up to 12 light bars per unit	

Weight	8kg (17.6 lbs)
Dimensions	400 x 256 x 100mm (15.7 x 10.1 x 3.9 in)
Cable Length	2 m (6ft 5in) PSU to plug

Certified for: IP66, CE, ROHS, cETLus

## Spectral Variants

\*Output measurements include Far-red.

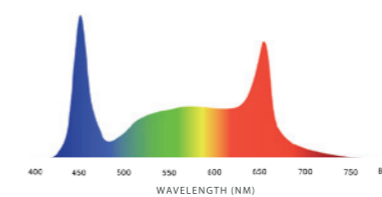

**helioSPEC Propagation**

2.0  $\mu\text{mol}/\text{J}^*$

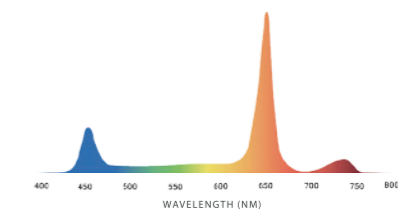

**helioSPEC Izar**

2.8  $\mu\text{mol}/\text{J}^*$

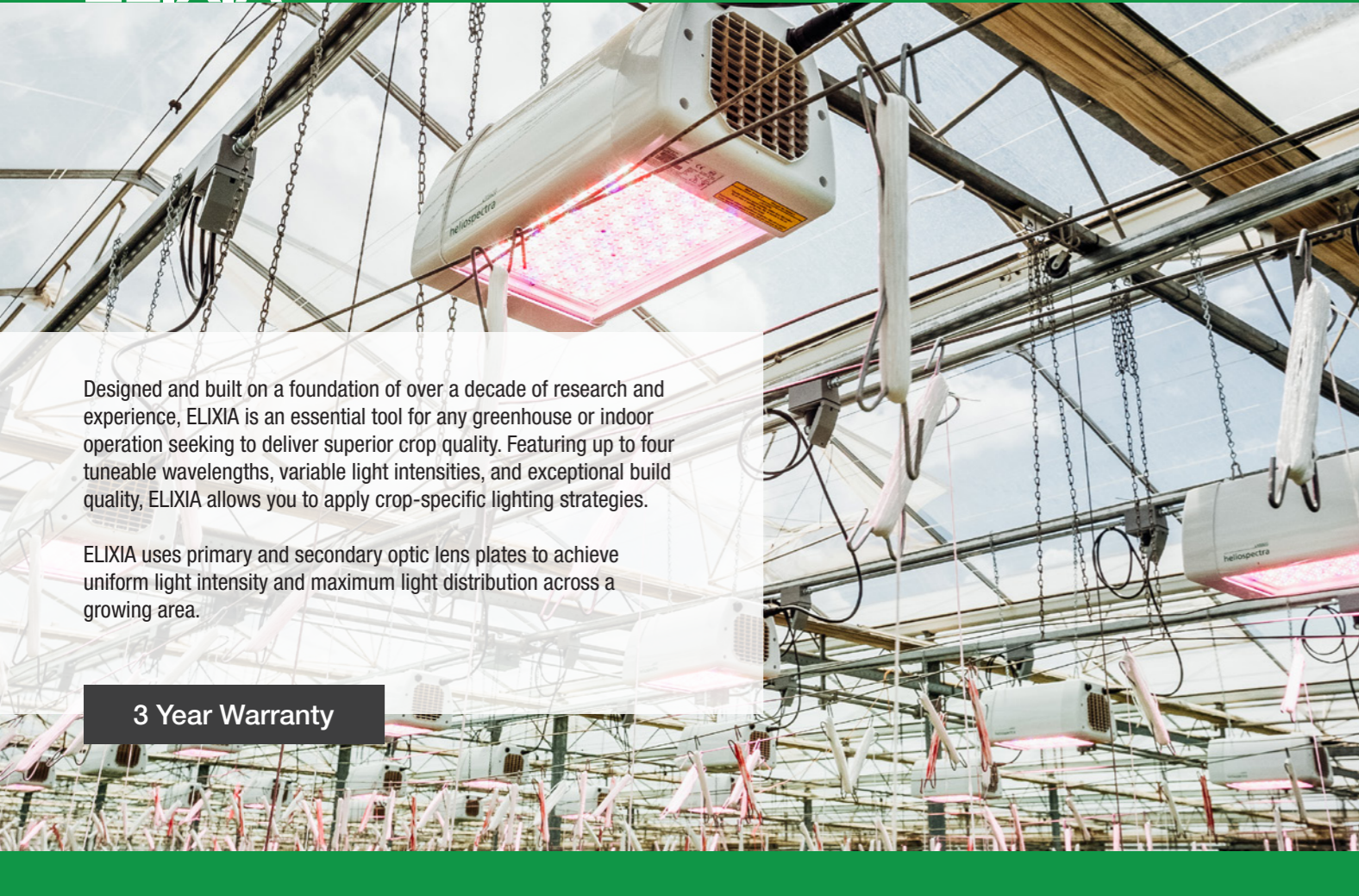

Designed and built on a foundation of over a decade of research and experience, ELIXIA is an essential tool for any greenhouse or indoor operation seeking to deliver superior crop quality. Featuring up to four tuneable wavelengths, variable light intensities, and exceptional build quality, ELIXIA allows you to apply crop-specific lighting strategies.

ELIXIA uses primary and secondary optic lens plates to achieve uniform light intensity and maximum light distribution across a growing area.

**3 Year Warranty**

Easy Installation & Connectivity

Endless Crop-Specific Lighting Options

Uniform Light Distribution



Wattage	Dimensions	Weight	Heat value	Thermal management	Max temp	Life time	Beam angle
10.5 - 600 W	199 x 219 x 425 mm	8kg	Up to 2047 BTUs/hr	Active Fan Cooling	40 °C (104 F) (35 °C (95 F) for > 347 VAC)	L90 > 50 000h	120°

## Electrical Specifications 600W Series

Voltage	120 VAC	240 VAC	277 VAC	347 VAC	400 VAC	480 VAC
<b>Amperage</b>	4.45 A	2.22 A	1.93 A	1.54 A	1.33 A	1.11 A
<b>Frequency</b>	50/60 Hz					
<b>Power Factor</b>	> 0.93					
<b>Inrush Current</b>	-	70A (30ms)	-	-	-	-

## Installation Specifications

<b>Mounting</b>	DIN M6 I-Hooks (Premounted)	
<b>Cable Length</b>	2m (6ft 5in) Detachable cable 120-277 VAC	2m (6ft 5in) Fixed cable 347-480 VAC
<b>Plug</b>	Nema 5-15, Nema 6-15, Schuko, JS	Open-ended

## Optics

Available in a choice of Narrow (02) or Wide Options (01)

### Narrow (Optic - 02)

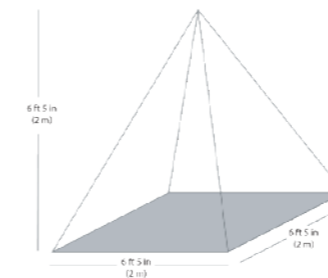

### Wide (Optic - 01)

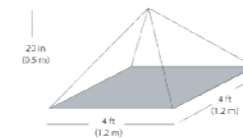

## Fixture Dimensions

### ELIXIA - Bottom View

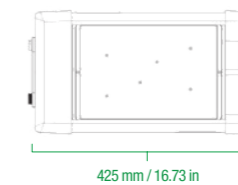

### ELIXIA - Rear View

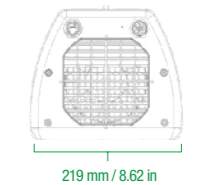

### ELIXIA - Top View



### ELIXIA - Side View

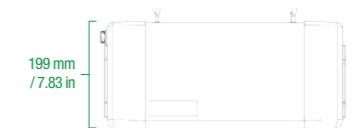

## Spectral Variants

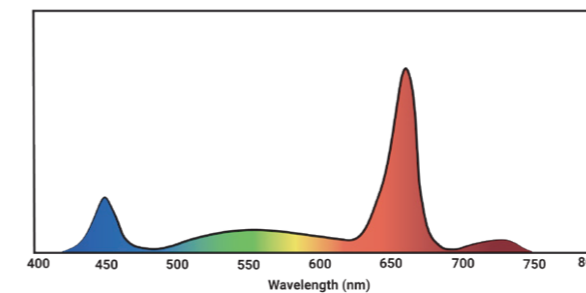

**C-Plate**

Up to 2.0 μmol/J

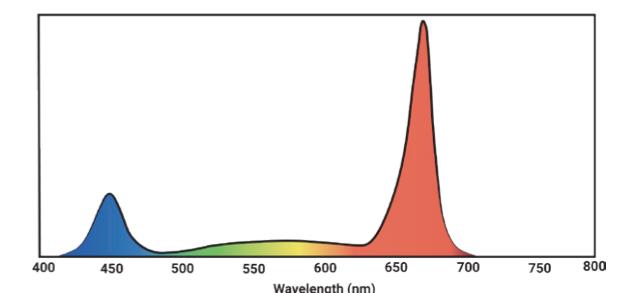

**G-Plate**

Up to 2.0 μmol/J

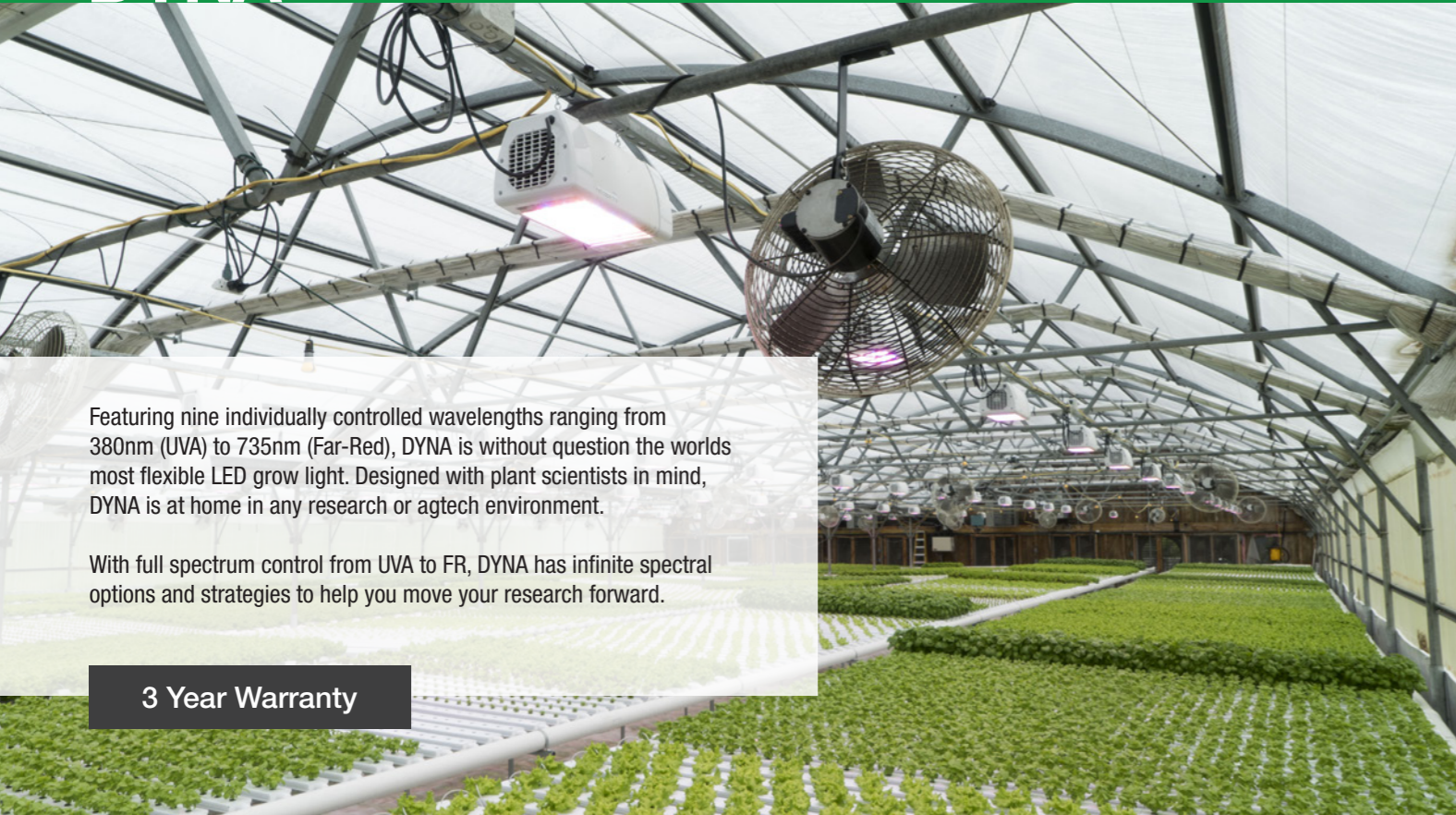

Featuring nine individually controlled wavelengths ranging from 380nm (UVA) to 735nm (Far-Red), DYNA is without question the worlds most flexible LED grow light. Designed with plant scientists in mind, DYNA is at home in any research or agtech environment.

With full spectrum control from UVA to FR, DYNA has infinite spectral options and strategies to help you move your research forward.

**3 Year Warranty**



Power Usage	Dimensions	Input Voltage	Max Current	Operating Temp	Storage Temp	Heat Value	Lifetime	Plug options	Ingress Protection
10.5 to 390 W	199 x 219 x 425 mm	100 to 277 VAC 50/60 Hz	2.9 A @ 120V 1.45 A @ 240V 1.25 A @ 277V	-10-40 °C	-20 to 70° C	Up to 1330 BTUs/hr	50 000 hrs (rated life to 90% of initial photon flux)	Nema 5-15, Nema 6-15, Schuko or Open-ended	IP24





Fully customisable Grow Chamber and Environmental Control Room solutions.

